

400GBASE-SR8 100m@OM4 QSFPDD Optical Transceiver with DDM

ZFTGS8G0850A5xx

## PRODUCT FEATURES

- QSFPDD MSA compliant
- 8 independent parallel optical channels
- Each channel data rate up to 26.56GBaud with CDR
- Hot Pluggable
- Up to 100m link on OM4 Multi-mode
- 850nm VCSEL/PD Array Technology
- CML Compatible electrical I/O
- QSFP-DD MSA Compliance
- Optical connectivity via industry standard MPO/MTP terminated fiber ribbon
- MPO-16 APC Optical Receptacle Type
- CMIS 4.0 Compliance
- Monitors for VCSEL bias, transmitted, received power, module temperature, and module supply
- Case Operating Temperature:
  - Commercial: 0 to 70°C
  - RoHS II Compliance

## APPLICATIONS

- High performance computing interconnect
- Data center

## COMPLIANCE

- QSFP-DD MSA.
- IEEE802.3cd
- RoHS 2.0
- CMIS 4.0

## Ordering information

Part Number	Data Rate(Gb/s)	Media	Wavelength(nm)	Operating distance(m)	Temperature(°C)
ZFTGS8G0850A5xx	8X53.125	MMF	850	70@OM3/100@OM4	0~70

## PRODUCT DESCRIPTION

ZFTGS8G0850A5xx is a QSFP-DD Optical transceiver for 8 x 26.56GBaud optical links. It is compliant with the QSFP-DD MSA specifications. It operates at 26.56GBaud up to 100m over OM4 Multi-mode fiber.

### 1. Block Diagram

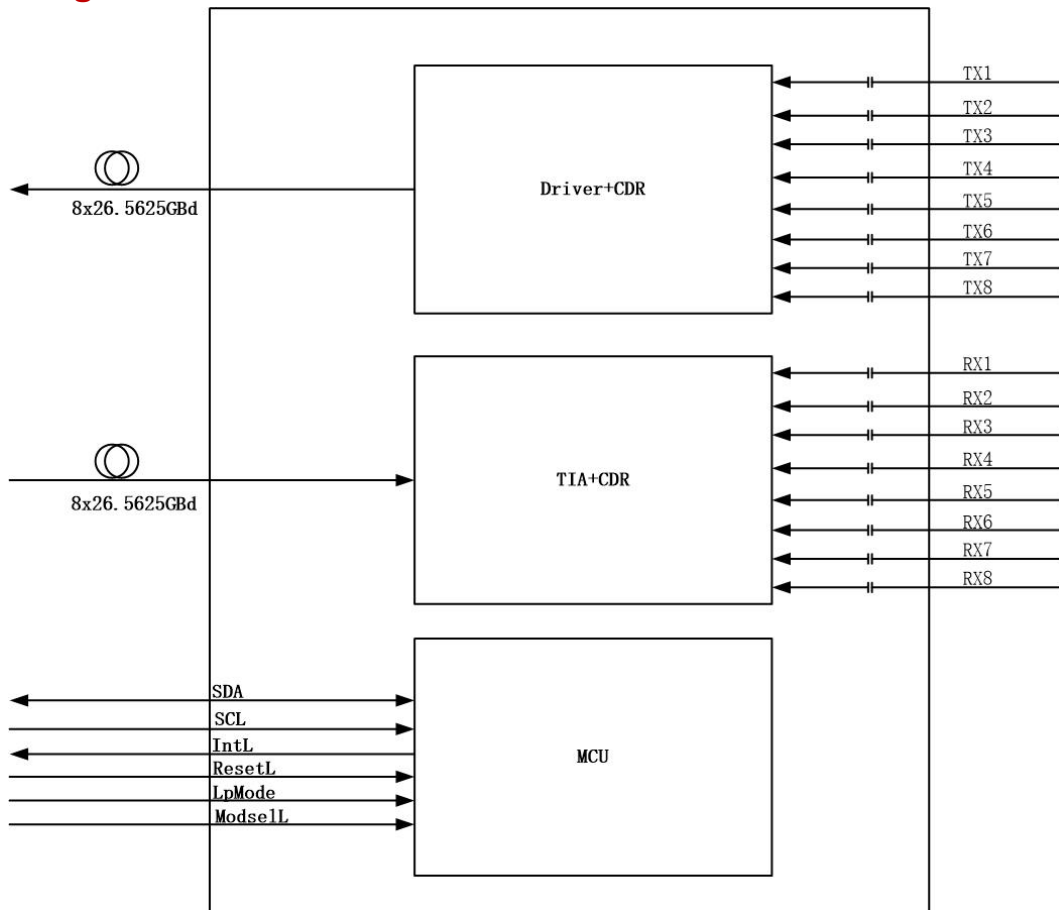

### 2. Pin Diagram

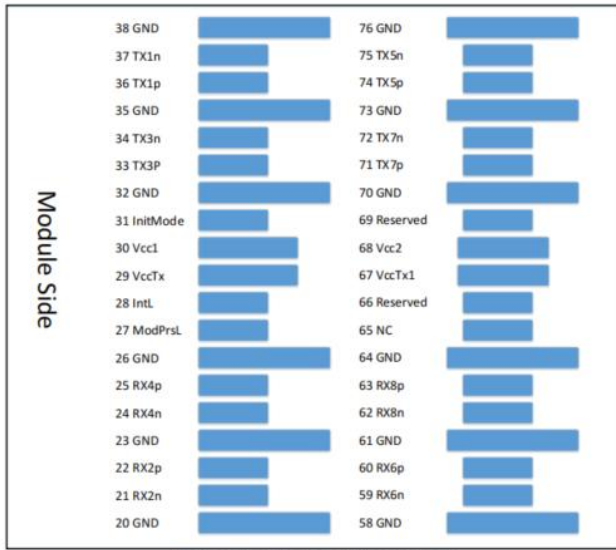

Top side viewed from top

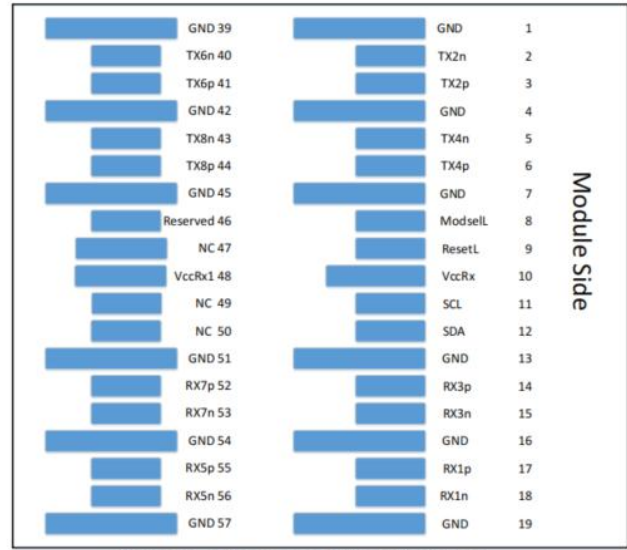

Bottom side viewed from bottom

### 3. Pin Descriptions

Pin	Symbol	Description	Notes
1	GND	Ground	
2	Tx2n	Transmitter Inverted Data Input	
3	Tx2p	Transmitter Non Inverted Data Input	
4	GND	Ground	
5	Tx4n	Transmitter Inverted Data Input	
6	Tx4p	Transmitter Non Inverted Data Input	
7	GND	Ground	
8	ModselL	Module Select	
9	ResetL	Module Reset	
10	VCC Rx	Receiver +3.3V DC Power Supply	
11	SCL	I2C Serial Clock	
12	SDA	I2C Serial Data	
13	GND	Ground	
14	Rx3p	Receiver Non Inverted Differential Output	
15	Rx3n	Receiver Inverted Differential Output	
16	GND	Ground	
17	Rx1p	Receiver Non Inverted Differential Output	
18	Rx1n	Receiver Inverted Differential Output	
19	GND	Ground	
20	GND	Ground	
21	Rx2n	Receiver Inverted Differential Output	
22	Rx2p	Receiver Non Inverted Differential Output	
23	GND	Ground	
24	Rx4n	Receiver Inverted Differential Output	
25	Rx4p	Receiver Non Inverted Differential Output	
26	GND	Ground	
27	ModPrstL	Module Present	
28	IntL	Interrupt	
29	VCC Tx	Transmitter +3.3V DC Power Supply	
30	VCC1	+3.3V DC Power Supply	

400GBASE-SR8 100m@OM4 QSFPDD Optical Transceiver with DDM

ZFTGS8G0850A5xx

31	Init Mode	Initialization Mode	
32	GND	Ground	
33	Tx3p	Transmitter Non Inverted Data Input	
34	Tx3n	Transmitter Inverted Data Input	
35	GND	Ground	
36	Tx1p	Transmitter Non Inverted Data Input	
37	Tx1n	Transmitter Inverted Data Input	
38	GND	Ground	
39	GND	Ground	
40	Tx6n	Transmitter Inverted Data Input	
41	Tx6p	Transmitter Non Inverted Data Input	
42	GND	Ground	
43	Tx8n	Transmitter Inverted Data Input	
44	Tx8p	Transmitter Non Inverted Data Input	
45	GND	Ground	
46	Reserved	No connect	
47	NC	No connect	
48	VCC Rx1	+3.3V DC Power Supply	
49	NC	No connect	
50	NC	No connect	
51	GND	Ground	
52	Rx7p	Receiver Non Inverted Differential Output	
53	Rx7n	Receiver Inverted Differential Output	
54	GND	Ground	
55	Rx5p	Receiver Non Inverted Differential Output	
56	Rx5n	Receiver Inverted Differential Output	
57	GND	Ground	
58	GND	Ground	
59	Rx6n	Receiver Inverted Differential Output	
60	Rx6p	Receiver Non Inverted Differential Output	
61	GND	Ground	
62	Rx8n	Receiver Inverted Differential Output	
63	Rx8p	Receiver Non Inverted Differential Output	
64	GND	Ground	
65	NC	No Connect	
66	Reserved	No Connect	
67	VCCTx1	+3.3V DC Power Supply	
68	VCC2	+3.3V DC Power Supply	
69	Reserved	No Connect	
70	GND	Ground	
71	Tx7p	Transmitter Non Inverted Data Input	
72	Tx7n	Transmitter Inverted Data Input	
73	GND	Ground	
74	Tx5p	Transmitter Non Inverted Data Input	

400GBASE-SR8 100m@OM4 QSFPDD Optical Transceiver with DDM	ZFTGS8G0850A5xx
---	-----------------

75	Tx5n	Transmitter Inverted Data Input	
76	GND	Ground	

## 4. Absolute Maximum Ratings

Parameter	Symbol	Min	Max	Units	Notes
Storage Ambient Temperature	Tstg	-40	+85	°C	Exceeding the Absolute Maximum Ratings may cause irreversible damage to the device. The device is not intended to be operated under the condition of simultaneous Absolute Maximum Ratings, a condition which may cause irreversible damage to the device. RH is Non-condensing condition.
Relative Humidity - Storage	RH <sub>s</sub>	0	95	%	
Relative Humidity - Operating	RH <sub>o</sub>	0	85	%	
Module Supply Voltage	V <sub>CC</sub>	-0.5	3.6	V	

## 5. Recommended Operating Conditions

Parameter	Symbol	Min	Typ	Max	Units	Notes
Case Operating Temperature	T <sub>case</sub>	0	+25	+70	°C	Temperature Range = C
Module Supply Voltage	V <sub>CC</sub>	3.14	3.3	3.46	V	
Power Consumption	P	-	-	10	W	
Signaling Speed Per Channel	S	-	26.56	-	GB	

## 6. Electrical Characteristics

Parameter	Symbol	Min	Typ	Max	Units	Notes
<b>Transmitter</b>						
Tx_Data Differential Input Voltage	V <sub>IN</sub>	-	-	900	mV	
Tx_Data Differential Input Impedance	Z <sub>IN</sub>	-	100	-	Ω	
<b>Receiver</b>						
Rx_Data Differential Output Voltage	V <sub>OUT</sub>	-	-	900	mV	
Rx_Data Differential Output Impedance	Z <sub>OUT</sub>	-	100	-	Ω	

## 7. Optical Characteristics

Parameter	Symbol	Min	Typ	Max	Units	Notes
<b>Transmitter</b>						
Signaling rate, each lane	SR	-	26.56	-	GBd	
Signaling Speed Accuracy	SSA	-100		100	ppm	
Modulation format		PAM4				
Average Launch Power ,each lane	P <sub>OUT</sub>	-6.5	-	4	dBm	Average Optical Output
Outer Optical Modulation Amplitude each lane	OMA <sub>outer</sub>	-4.5	-	3	dBm	
Optical Output with Tx OFF	P <sub>OFF</sub>	-	-	-30	dBm	
Extinction ratio	ER	3			dB	
Center Wavelength	λ	840	850	868	nm	
RMS Spectral Width	Δλ	-	-	0.6	nm	

400GBASE-SR8 100m@OM4 QSFPDD Optical Transceiver with DDM	ZFTGS8G0850A5xx
---	-----------------

Transmitter and dispersion eye closure (TDECQ) each lane	TDECQ	-	-	4.5	dB	
Launch power in OMA <sub>outer</sub> minus TDECQ, each lane (min)		-5.9	-	-	dB	
TDECQ – 10log <sub>10</sub> (C <sub>eq</sub> ), each lane (max)		-	-	4.5	dB	
RIN <sub>12</sub> OMA	RIN <sub>12</sub> OMA	-	-	-128	dB/Hz	
Optical return loss tolerance (Max)	ORLT			12	dB	
<b>Receiver</b>						
Signaling rate, each lane	SR	-	26.56	-	GBd	
Signaling Speed Accuracy		-100		100	ppm	
Modulation format		PAM4				
Average power at receive input, each lane	P <sub>IN</sub>	-8.4	-	4	dBm	1
Receive power (OMA <sub>outer</sub> ), each lane (max)		-	-	3	dBm	
Receiver sensitivity (OMA <sub>outer</sub> ) each lane	Sen	-	-	max(-6.6, SECQ – 8)	dBm	2
Center Wavelength	λ	840	850	868	nm	
Rx_LOS of Signal - Assert	PA	-24.6	-	-	dBm	
Rx_LOS of Signal - Deassert	PD	-	-	-7	dBm	
Rx_LOS of Signal - Hysteresis	PHY	0.5	-	-	dB	

Notes:

1. Average received power where the BER=2.4E-4 measured with a PRBS31Q test pattern@26.56GBaud.
2. Sensitivity where the BER = 2.4E-4 measured with a PRBS 31Q test pattern@26.56GBaud.

## 8. Mechanical Specifications

